

(19)



Europäisches Patentamt
European Patent Office
Office européen des brevets



(11)

EP 0 974 713 A1

(12)

EUROPEAN PATENT APPLICATION

(43) Date of publication:
26.01.2000 Bulletin 2000/04

(51) Int. Cl.⁷: E04F 15/04

(21) Application number: 99202272.3

(22) Date of filing: 10.07.1999

(84) Designated Contracting States:
AT BE CH CY DE DK ES FI FR GB GR IE IT LI LU
MC NL PT SE
Designated Extension States:
AL LT LV MK RO SI

(72) Inventor:
Thiers, Bernard Paul Joseph
8780 Oostrozebeke (BE)

(74) Representative: Donné, Eddy
Bureau M.F.J. Bockstael nv
Arenbergstraat 13
2000 Antwerpen (BE)

(30) Priority: 24.07.1998 BE 9800561
14.04.1999 BE 9900256

(71) Applicant: Unilin Beheer B.V.
2913 LV Nieuwerkerk aan de IJssel (NL)

(54) **Floor covering, floor panel for such covering and method for the realization of such floor panel**

(57) Floor covering, consisting of floor panels (1) based on a fibre-like material bound by a binding agent, more particularly MDF or HDF, which, at least at their edges, are connected to each other by means of a connection, more particularly a tongue-and-groove connection (2-3), which connection consists of coupling parts which are made in one piece with the floor panels and is shaped in such a manner that the floor panels (1) are

locked glue-free in the direction parallel to the plane of the floor covering and transverse to the connection, as well as in a direction perpendicular to this plane, characterized in that, at least at the location where the floor panels (1) cooperate with each other, a sliding agent (12-12A) is provided at least on one of the floor panels (1).

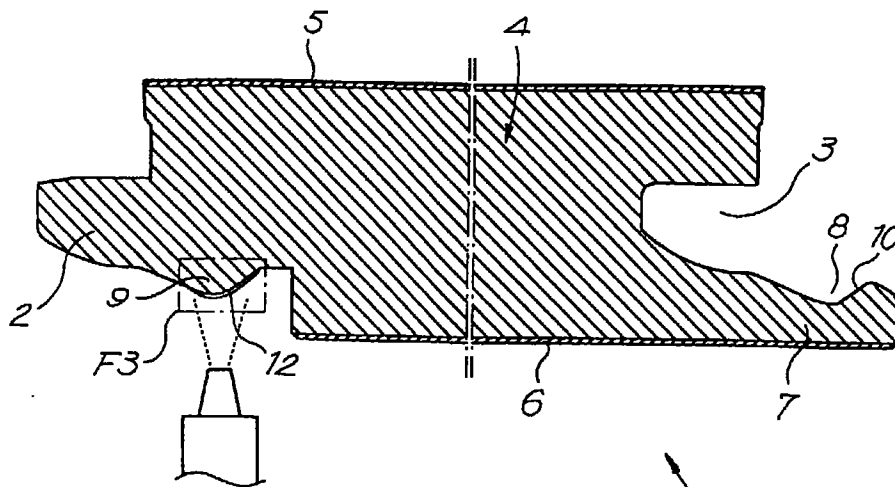

Fig. 2

EP 0 974 713 A1

Description

[0001] This invention relates to a floor covering, a floor panel for the realization of such floor covering, as well as a method for the realization of such floor panel.

[0002] More particularly, it relates to a floor covering consisting of floor panels which, at least at their edges, are connected to each other by means of a connection, more particularly a tongue-and-groove connection, which connection consists of coupling parts which are made in one piece with the floor panels and is shaped in such a manner that the floor panels are locked glue-free in the direction parallel to the plane of the floor covering and transverse to the connection, as well as in a direction perpendicular to this plane. Such floor covering is described in the European patent application No. 0.843.763.

[0003] The floor panels can be joined together very fast by means of clicking and/or turning and are connected firmly without the necessity of using glue. It is also possible to disconnect these floor panels, after which they can be used again at another location.

[0004] When the floor covering is stepped on, it may occur that two adjacent panels undergo a minimal bending and, thus, carry out a movement in respect to each other. This is increased as the floor panels are always placed on an insulating and somewhat resilient under-ground.

[0005] This movement between the floor panels may result in a creaking noise, due to the friction which is created at the surfaces which are in contact with each other, first of all because the coupling has locking surfaces between two panels which extend in another than the horizontal direction.

[0006] It was noted that this phenomenon occurs in the first place with floor panels which are made on the basis of a glued fibre-like material, more particularly MDF or HDF.

[0007] In spite of the fact that by the use of tongue-and-groove connections of MDF or HDF, a rather smooth surface is obtained, as a result of which the aforementioned clicking and/or turning into each other takes place in a particularly easy manner, in the long range wear and tear may result from the mutual movement of the floor panels, as a result of which the trouble-free fitting of the floor panels can be influenced disadvantageously.

[0008] This invention in first instance aims at a floor covering which is improved. More particularly does the invention aim at a floor covering in which the aforementioned and other disadvantages are avoided and, when being stepped upon, the creaking between the floor panels is excluded, whereas in the long range the wear and tear of the tongue-and-groove connection also is limited.

[0009] According to the invention, this aim is achieved in that at least at the location where the floor panels cooperate with each other, under which generally the

tongue-and-groove connection has to be understood, at least on one of the floor panels a sliding agent is applied, this beforehand in the factory, for example, subsequent to the fabrication of the floor panels.

[0010] Due to the presence of this sliding agent, the floor panels, with the coupling parts of their tongue-and-groove connection, can slide over each other without thereby creating an perceptible sound. Due to the presence of the sliding agent, the friction, moreover, is reduced, as a result of which there is less wear and tear. If the sliding agent is provided at well-defined locations, this, as will be explained hereafter, also renders the effect that the floor panels can be joined easier, as the sliding agent is reducing the resistance during the joining.

[0011] Preferably, a sliding agent is applied in the form of a layer which lies at least partially on top of the surface of the edge, both edges, respectively, concerned. By working with a layer on top, a good lubricating and sliding function is obtained.

[0012] According to a first possibility, the sliding agent is applied substantially over the entire surface of the edge of at least one of the floor panels.

[0013] According to a particular second embodiment, however, the sliding agent is applied in the form of one or more local strips extending in longitudinal direction at the tongue-and-groove connection. Due to the provision of the sliding agent in the form of strips, it can easily be applied in a continuous process. Moreover, by applying such strip locally, it is possible to prevent that, by the deformation of the sliding agent, this latter is pushed beyond the tongue-and-groove connection, as a result of which a soiling at the upper side of the floor covering is excluded. Moreover, by local application in the form of a strip, it is obtained that the sliding agent can be applied efficiently at the location where it is desired, as a result of which the applied quantity can be kept limited.

[0014] The local application has also as an advantage that the strip may consist of a relatively thick layer of this sliding agent without creating any disadvantage.

[0015] More particularly, it is preferred that precisely one strip is applied.

[0016] Each respective strip in original, undeformed condition preferably shows a width of maximum 4 mm.

[0017] The strip does not have to be continuous and may, for example, also consist of a succession of line portions, dots, and so on.

[0018] Preferably, the sliding agent is kept away from the upper edge of the floor panel, with the advantage that the sliding agent, when deformed, can not appear at the upper side of the floor covering. In first instance, this is of importance when a strip of some thickness is applied.

[0019] Still more particularly, it is preferred that between the upper edge and the strip of sliding agent applied on top which is situated closest to the upper edge when seen along the contour of the surface, a

receiving space is present, as a result of which possible surplus sliding agent which is pressed aside can be taken up, in such a manner that it is completely excluded that the sliding agent can move up to the upper side. Such an intermediate receiving space may also be provided in the direction towards the lower edge.

[0020] As already becomes clear from the foregoing, preferably a deformable material is applied as a sliding agent.

[0021] More particularly, this sliding agent preferably is plastically deformable and, for example, meltable, but set at room temperature, such that, during the manufacturing of the floor panels, it may be sprayed or be applied by means of a supply nozzle, in liquid form.

[0022] Suitable sliding agents are, amongst others, wax, in particular, paraffin.

[0023] It is noted that impregnating a tongue and groove of floor panels with paraffin is known but that this is performed to render the tongue-and-groove connection more resistive against the penetration of water. Hereby, the paraffin is applied over the entire surface of the tongue and groove and this in such a way that the paraffin completely penetrates into the surface. As a result thereof, this paraffin can not remedy the aforementioned problems arising with a tongue-and-groove connection with an engagement under a certain tension.

[0024] According to the invention, the sliding agent, more particularly, the paraffin, however is applied in such a manner that a lubricating and/or sliding effect and, even better, a lubricating film is obtained. The necessary quantity of sliding agent depends on the material of the floor panels, the shape of the coupling and, eventually, when there is a tension between the floor parts, the value of this tension. This necessary quantity can be determined by tests.

[0025] In the case of a layer "lying on top", the thickness with which the sliding agent is provided, preferably is at least such that, at least with a glossy-looking sliding agent, visually also a glossy surface remains after the application. More particularly, it is preferred that the layer of sliding agent in such case has an average thickness in the order of magnitude of 0,05 mm or more, although smaller thicknesses principally are not excluded.

[0026] According to the invention, the tongue and/or groove can also be treated with a surface treatment product for sealing and/or hardening the surface, in which case the sliding agent is applied on top of this product, as a result of which the additional advantage is obtained that the sliding agent will not penetrate into the floor panels after a certain period of time.

[0027] According to a particular form of embodiment of the invention, the surface of the edge of the floor panel is treated at least partially, but preferably entirely with a liquid mixture of at least one sealing agent and one sliding agent. By means of this treatment method

which is performed in the factory, it is obtained that in one treatment simultaneously a seal against humidity penetration, as well as a lubrication effect is obtained. Such mixture has as a result that, after the application thereof on the milled tongue-and-groove profile, the sealing agent is absorbed in the material of the floor panel and fills the pores thereof, whereas the sliding agent remains at the surface. In this case, the sliding agent preferably consists of polyurethane, and the sliding agent of a wax, an oil or an oil-like substance.

[0028] The application of the mixture may take place in any manner, by atomization, spraying, application by means of small rollers, etc.

[0029] More particularly may the above-said be combined with the use of a strip of sliding agent applied on top, whereby then, at the location of this strip, a relatively thick layer of sliding agent is present, whereas a smaller quantity is present on the rest of the surface.

[0030] The tongue and the groove of the tongue-and-groove connection preferably have such a form that, in coupled position, they exert a certain tensioning force upon each other, in a preferred form of embodiment a tensioning force by means of which the mutually coupled floor panels are forced towards each other, in which case the strip of sliding agent is at least present on one or more portions of the contact surfaces of the tongue and/or the groove where this tensioning force is exerted. It is in fact at these portions where the largest friction occurs and the risk is greatest that an undesired noise will be created when the floor covering is stepped on.

[0031] According to a particular form of embodiment, the floor covering is characterized in that the tongue-and-groove connection comprises one or more portions which bend elastically when being joined together, taken apart, respectively, this as certain portions of the coupling parts during joining, taking apart, respectively, are forced over each other with a certain force and that the aforementioned sliding agent at least is provided at the location of one or more of the portions which have to be forced over each other with a certain force. As a result thereof, it is achieved that the sliding agent also forms a lubricating agent, whereby fraying of the HDF or MDF is excluded, even if the floor panels are joined and taken apart repeatedly.

[0032] Moreover, in this case the sliding agent facilitates the mutual joining, by turning or clicking in, of the tongue and groove of a tongue-and-groove connection among two adjacent floor panels.

[0033] A portion of the floor panels limiting the groove may be an elastically bendable lip, and the shape of the tongue and groove may be such that the tongue only fits into the groove by bending this lip, whereby the sliding agent is applied on this lip or on the portion of the tongue opposite thereof.

[0034] The locking can be performed by a protrusion on the tongue and a recess in the wall of the groove. The sliding agent then preferably will be applied on this

protrusion.

[0035] According to a particular form of embodiment, the risk for creating creaking sounds can also be excluded, or at least minimized, by using an elastic coating instead of a sliding agent. To this aim, an elastic coating is applied at least on one of the floor panels, at least at the location where the floor panels cooperate with each other, which coating, during a mutual shifting between the cooperating portions of the actual floor panels, allows for a local deformation in the material of the coating, as a result of which the risk of shifting at the contact surface between the coatings themselves, or between the coating and the surface of the other floor panel, is excluded or at least minimized.

[0036] This invention also relates to a floor panel for the floor covering according to any of the preceding forms of embodiment which is characterized in that it is provided by the factory at least at one of its edges with a sliding agent or an elastic coating, as defined in the foregoing, as well as in the description following hereafter.

[0037] With the intention of better showing the characteristics of the invention, hereafter, as examples without any limitative character, several preferred forms of embodiment are described, with reference to the accompanying drawings, wherein:

figure 1 represents a view in perspective of a floor panel according to the invention;

figure 2 represents a cross-section according to line II-II in figure 1, drawn at a larger scale;

figure 3, at an even larger scale, represents the part which is indicated by F3 in figure 2;

figures 4 and 5 in cross-section represent two floor panels according to the invention, during the mutual coupling and locking in respect to each other;

figure 6 in cross-section represents the two floor panels after having been coupled to each other;

figure 7 in cross-section represents a variant;

figure 8 schematically represents an enlargement of the portion indicated by F8 in figure 7;

figure 9 represents another variant of the invention;

figure 10 represents a portion of a particular form of embodiment.

[0038] The floor covering according to the invention consists of hard floor panels 1, as represented in figures 1 to 3, which are mutually coupled in a glueless fashion by means of a tongue-and-groove connection, consisting of a tongue 2 and a groove 3 of a particular shape.

[0039] The represented floor panel 1 is a laminate panel and consists of a hard core 4 made of MDF plate, HDF plate, or similar, a coating 5 at the step-up side, and a coating 6 at the rear side.

[0040] The coating 5 may be multi-layered and comprises, for example, a decorative layer with a protective transparent resin layer thereupon. The coating 6 may consist of a paper layer impregnated with resin or such.

[0041] This floor panel 1 is rectangular, but may also have other shapes. This floor panel 1 has a tongue 2 at one longitudinal edge over its entire length, whereas its opposite longitudinal edge has a groove 3 over its entire length.

[0042] In an analogous manner, such tongue 2 preferably is also present at one perpendicular edge, whereas the opposite perpendicular edge is provided with such a groove 3.

[0043] In cross-section, the tongue 2 and groove 3 have such a form that a tongue 2 of a floor panel 1 can be brought by turning or clicking into a groove 3 of a similar second floor panel 1 and that after coupling a locking is obtained, in the direction parallel to the plane of the floor covering, transverse to the tongue-and-groove connection 2-3, as well as in the direction which is perpendicular to this plane and, thus, vertical, whereby the coupling parts of the tongue-and-groove connection 2-3, in other words, the tongue 2 and the groove 3 in coupled position, preferably exert a tensioning force upon each other, as a result of which the coupled floor panels 1 are forced towards each other.

[0044] In the example represented in figures 1 to 3, this is realized in that each floor panel 1, at the side of the groove 3, comprises an elastically bendable lip 7 in which a recess 8 is provided over the entire length, whereas the tongue 2 has at its underside a protrusion 9 over its entire length.

[0045] This protrusion 9 is placed at such a location and has such a shape that, when the tongue 2 of a floor panel 1 is provided in a groove 3 of an identical floor panel 1 coupled thereto, the side of the recess 8 in this groove 3 directed to the center of the first floor panel 1 with an inclined surface 10 comes into contact with an inclined contact surface 11 of the side of the protrusion 9 of this tongue 2 directed to the center of the first-mentioned floor panel 1.

[0046] These contact surfaces 10 and 11 which are directed inclined in respect to the stepping side and the rear side of the floor panels 1 moreover fit against each other with a certain tensioning force which is caused in that the elastically bendable lip 7 bordering the last-mentioned groove 3, in coupled position of two floor panels 1, is bent in an extremely small order, for example, over several hundreds to tenths of a millimeter, and therefore provides for a compressing force in vertical direction.

[0047] It is noted that the form of the tongue-and-groove connection 2-3 thereby is such that the tensioning force which forces the floor panels 1 towards each other, substantially exerts a pressure only at two places, on one hand, by means of a line contact at the location of the upper edge where the decorative layer is situated, and, on the other hand, a band-shaped contact, formed at the contact surfaces 10 and 11.

[0048] Due to this recess 8 and this protrusion 9 and furthermore the conventional engagement of the tongue 2 in the groove 3, the floor panels 1 are locked in a

receiving space is present, as a result of which possible surplus sliding agent which is pressed aside can be taken up, in such a manner that it is completely excluded that the sliding agent can move up to the upper side. Such an intermediate receiving space may also be provided in the direction towards the lower edge.

[0020] As already becomes clear from the foregoing, preferably a deformable material is applied as a sliding agent.

[0021] More particularly, this sliding agent preferably is plastically deformable and, for example, meltable, but set at room temperature, such that, during the manufacturing of the floor panels, it may be sprayed or be applied by means of a supply nozzle, in liquid form.

[0022] Suitable sliding agents are, amongst others, wax, in particular, paraffin.

[0023] It is noted that impregnating a tongue and groove of floor panels with paraffin is known but that this is performed to render the tongue-and-groove connection more resistive against the penetration of water. Hereby, the paraffin is applied over the entire surface of the tongue and groove and this in such a way that the paraffin completely penetrates into the surface. As a result thereof, this paraffin can not remedy the aforementioned problems arising with a tongue-and-groove connection with an engagement under a certain tension.

[0024] According to the invention, the sliding agent, more particularly, the paraffin, however is applied in such a manner that a lubricating and/or sliding effect and, even better, a lubricating film is obtained. The necessary quantity of sliding agent depends on the material of the floor panels, the shape of the coupling and, eventually, when there is a tension between the floor parts, the value of this tension. This necessary quantity can be determined by tests.

[0025] In the case of a layer "lying on top", the thickness with which the sliding agent is provided, preferably is at least such that, at least with a glossy-looking sliding agent, visually also a glossy surface remains after the application. More particularly, it is preferred that the layer of sliding agent in such case has an average thickness in the order of magnitude of 0,05 mm or more, although smaller thicknesses principally are not excluded.

[0026] According to the invention, the tongue and/or groove can also be treated with a surface treatment product for sealing and/or hardening the surface, in which case the sliding agent is applied on top of this product, as a result of which the additional advantage is obtained that the sliding agent will not penetrate into the floor panels after a certain period of time.

[0027] According to a particular form of embodiment of the invention, the surface of the edge of the floor panel is treated at least partially, but preferably entirely with a liquid mixture of at least one sealing agent and one sliding agent. By means of this treatment method

which is performed in the factory, it is obtained that in one treatment simultaneously a seal against humidity penetration, as well as a lubrication effect is obtained. Such mixture has as a result that, after the application thereof on the milled tongue-and-groove profile, the sealing agent is absorbed in the material of the floor panel and fills the pores thereof, whereas the sliding agent remains at the surface. In this case, the sliding agent preferably consists of polyurethane, and the sliding agent of a wax, an oil or an oil-like substance.

[0028] The application of the mixture may take place in any manner, by atomization, spraying, application by means of small rollers, etc.

[0029] More particularly may the above-said be combined with the use of a strip of sliding agent applied on top, whereby then, at the location of this strip, a relatively thick layer of sliding agent is present, whereas a smaller quantity is present on the rest of the surface.

[0030] The tongue and the groove of the tongue-and-groove connection preferably have such a form that, in coupled position, they exert a certain tensioning force upon each other, in a preferred form of embodiment a tensioning force by means of which the mutually coupled floor panels are forced towards each other, in which case the strip of sliding agent is at least present on one or more portions of the contact surfaces of the tongue and/or the groove where this tensioning force is exerted. It is in fact at these portions where the largest friction occurs and the risk is greatest that an undesired noise will be created when the floor covering is stepped on.

[0031] According to a particular form of embodiment, the floor covering is characterized in that the tongue-and-groove connection comprises one or more portions which bend elastically when being joined together, taken apart, respectively, this as certain portions of the coupling parts during joining, taking apart, respectively, are forced over each other with a certain force and that the aforementioned sliding agent at least is provided at the location of one or more of the portions which have to be forced over each other with a certain force. As a result thereof, it is achieved that the sliding agent also forms a lubricating agent, whereby fraying of the HDF or MDF is excluded, even if the floor panels are joined and taken apart repeatedly.

[0032] Moreover, in this case the sliding agent facilitates the mutual joining, by turning or clicking in, of the tongue and groove of a tongue-and-groove connection among two adjacent floor panels.

[0033] A portion of the floor panels limiting the groove may be an elastically bendable lip, and the shape of the tongue and groove may be such that the tongue only fits into the groove by bending this lip, whereby the sliding agent is applied on this lip or on the portion of the tongue opposite thereof.

[0034] The locking can be performed by a protrusion on the tongue and a recess in the wall of the groove. The sliding agent then preferably will be applied on this

protrusion.

[0035] According to a particular form of embodiment, the risk for creating creaking sounds can also be excluded, or at least minimized, by using an elastic coating instead of a sliding agent. To this aim, an elastic coating is applied at least on one of the floor panels, at least at the location where the floor panels cooperate with each other, which coating, during a mutual shifting between the cooperating portions of the actual floor panels, allows for a local deformation in the material of the coating, as a result of which the risk of shifting at the contact surface between the coatings themselves, or between the coating and the surface of the other floor panel, is excluded or at least minimized.

[0036] This invention also relates to a floor panel for the floor covering according to any of the preceding forms of embodiment which is characterized in that it is provided by the factory at least at one of its edges with a sliding agent or an elastic coating, as defined in the foregoing, as well as in the description following hereafter.

[0037] With the intention of better showing the characteristics of the invention, hereafter, as examples without any limitative character, several preferred forms of embodiment are described, with reference to the accompanying drawings, wherein:

figure 1 represents a view in perspective of a floor panel according to the invention;

figure 2 represents a cross-section according to line II-II in figure 1, drawn at a larger scale;

figure 3, at an even larger scale, represents the part which is indicated by F3 in figure 2;

figures 4 and 5 in cross-section represent two floor panels according to the invention, during the mutual coupling and locking in respect to each other;

figure 6 in cross-section represents the two floor panels after having been coupled to each other;

figure 7 in cross-section represents a variant;

figure 8 schematically represents an enlargement of the portion indicated by F8 in figure 7;

figure 9 represents another variant of the invention;

figure 10 represents a portion of a particular form of embodiment.

[0038] The floor covering according to the invention consists of hard floor panels 1, as represented in figures 1 to 3, which are mutually coupled in a glueless fashion by means of a tongue-and-groove connection, consisting of a tongue 2 and a groove 3 of a particular shape.

[0039] The represented floor panel 1 is a laminate panel and consists of a hard core 4 made of MDF plate, HDF plate, or similar, a coating 5 at the step-up side, and a coating 6 at the rear side.

[0040] The coating 5 may be multi-layered and comprises, for example, a decorative layer with a protective transparent resin layer thereupon. The coating 6 may consist of a paper layer impregnated with resin or such.

[0041] This floor panel 1 is rectangular, but may also have other shapes. This floor panel 1 has a tongue 2 at one longitudinal edge over its entire length, whereas its opposite longitudinal edge has a groove 3 over its entire length.

[0042] In an analogous manner, such tongue 2 preferably is also present at one perpendicular edge, whereas the opposite perpendicular edge is provided with such a groove 3.

[0043] In cross-section, the tongue 2 and groove 3 have such a form that a tongue 2 of a floor panel 1 can be brought by turning or clicking into a groove 3 of a similar second floor panel 1 and that after coupling a locking is obtained, in the direction parallel to the plane of the floor covering, transverse to the tongue-and-groove connection 2-3, as well as in the direction which is perpendicular to this plane and, thus, vertical, whereby the coupling parts of the tongue-and-groove connection 2-3, in other words, the tongue 2 and the groove 3 in coupled position, preferably exert a tensioning force upon each other, as a result of which the coupled floor panels 1 are forced towards each other.

[0044] In the example represented in figures 1 to 3, this is realized in that each floor panel 1, at the side of the groove 3, comprises an elastically bendable lip 7 in which a recess 8 is provided over the entire length, whereas the tongue 2 has at its underside a protrusion 9 over its entire length.

[0045] This protrusion 9 is placed at such a location and has such a shape that, when the tongue 2 of a floor panel 1 is provided in a groove 3 of an identical floor panel 1 coupled thereto, the side of the recess 8 in this groove 3 directed to the center of the first floor panel 1 with an inclined surface 10 comes into contact with an inclined contact surface 11 of the side of the protrusion 9 of this tongue 2 directed to the center of the first-mentioned floor panel 1.

[0046] These contact surfaces 10 and 11 which are directed inclined in respect to the stepping side and the rear side of the floor panels 1 moreover fit against each other with a certain tensioning force which is caused in that the elastically bendable lip 7 bordering the last-mentioned groove 3, in coupled position of two floor panels 1, is bent in an extremely small order, for example, over several hundreds to tenths of a millimeter, and therefore provides for a compressing force in vertical direction.

[0047] It is noted that the form of the tongue-and-groove connection 2-3 thereby is such that the tensioning force which forces the floor panels 1 towards each other, substantially exerts a pressure only at two places, on one hand, by means of a line contact at the location of the upper edge where the decorative layer is situated, and, on the other hand, a band-shaped contact, formed at the contact surfaces 10 and 11.

[0048] Due to this recess 8 and this protrusion 9 and furthermore the conventional engagement of the tongue 2 in the groove 3, the floor panels 1 are locked in a

direction parallel to the aforementioned sides of the floor panels 1 as well as in a direction vertical thereto.

[0049] The two lateral edges of the core 4, and, therefore, the tongue 2 as well as the groove 3, preferably are impregnated with a surface treatment product, for example, with polyurethane. This possible impregnation, however, is not indicated in figures 2 to 6.

[0050] The particularity of the invention consists in that at the edges of the floor panel 1, at the tongue 2 and/or the groove 3, a sliding agent 12 is provided.

[0051] According to the embodiment represented in figures 1 to 6, to this aim between the two contact surfaces 10 and 11, at least at one of these two, in this case, on the contact surface 11 of the tongue 2, a strip of sliding agent 12 is present.

[0052] The strip of sliding agent 11 is kneadable or plastically deformable, and the sliding agent therefore at room temperature is in solid form. It can be meltable such that it may be sprayed after heating and can be sprayed onto the tongue 2 by means of a spray nozzle, as represented in figure 2, or by means of a needle-shaped nozzle or in any other manner.

[0053] Suitable sliding agents are, as already mentioned, mineral or synthetic wax, such as paraffin. Paraffin is easy to melt (between 55 and 80°C, depending on the composition), but also sets very rapidly at room temperature after spraying. It can be sprayed by means of spraying devices and/or application nozzles available on the market. Moreover, it is an environmentally acceptable product.

[0054] In fact, the sliding agent 12 is provided over the tip of the protrusion 9 with a tangible thickness, in such a manner that the strip of sliding agent 12 extends at opposite sides of this tip, as represented clearly in figures 2 and 3. The strip of sliding agent 12 does not only cover the contact surface 11 at one side of the tip, but also a portion of the surface at the other side of the tip.

[0055] Bringing a tongue 2 into a groove 3 in order to couple two adjacent floor panels 1 to each other and lock them as well in vertical as in horizontal direction may take place by having one floor panel 1 undergo a downward pivoting movement during this mounting, as represented in figure 4, or by clicking them into each other by a sideways shifting movement, as represented in figure 5.

[0056] After two floor panels 1 have been coupled to each other with their longitudinal edges, the transverse edges of those floor panels 1 can be coupled to the other, for example, by clicking-in.

[0057] In both cases, but in the first place in the second case, the lip 7 temporarily is somewhat bent, and the tip of the protrusion 9, which is covered with the strip of sliding agent 12, has to push away a portion of the lip 7 with a certain force.

[0058] It is clear that the sliding agent 12 on this tip facilitates this by reducing the friction.

[0059] When the tongue 2 is completely engaged in the groove 3, as represented in figure 6, a thin layer of

sliding agent 12 will be present between the two contact layers 10 and 11, and a possible surplus of sliding agent 12 will have been pushed away, on one hand, into the small receiving space 13 which remains at the side of the tip situated opposite to the contact surfaces 10 and 11, between the tongue 2 and the lowermost wall of the groove 3, and, on the other hand, into the receiving space 14 between the end of the lip 7 of one floor panel 1 and the portion of the other floor panel 1 situated below the tongue 2.

[0060] In an extreme case, when, however, a surplus of sliding agent 12 has been applied, not only the receiving space 13, but also the receiving spaces 15 and 16 will provide for that the surplus sliding agent 12 is collected therein, in such a manner that this sliding agent 12 never will appear at the upper side of the floor covering.

[0061] When a floor covering consisting of the floor panels 1 described heretofore is stepped on, those floor panels 1, in the first place if they are placed upon a somewhat resilient underground, may perform a minor hinge-like movement in respect to each other without, however, creating a gap.

[0062] As a result of the fact that a sliding agent 12 is present on the aforementioned tip and between the contact surfaces 10 and 11, the aforementioned hinge-like movement will cause a minimum friction between the contact surfaces 10 and 11 such that, even after a long period of time, wear and tear will be very limited and no play will be created between a tongue 2 and its groove 3. There will also be no sound or creaking to be heard during this hinge-like movement.

[0063] The invention is in no way limited to the form of embodiment described heretofore and represented in the figures, on the contrary may such floor covering and such floor panel be realized in various variants without leaving the scope of the invention.

[0064] So, the sliding agent 12 may also be placed in the recess 8 instead of at the tip of the protrusion 9. In this case, too, the last-mentioned advantages are obtained. Sliding agent 12 may also be provided on the aforementioned tip as well as in the aforementioned recess 8.

[0065] The tongue 2 and the groove 3 may, of course, have another profile than described heretofore and represented in the figures. The invention will be particularly advantageous in those cases whereby the tongue 2 and the groove 3 allow for a glue-free coupling without play, with a locking in the plane of the floor covering as well as in a direction perpendicular thereto, whereby, thus, portions of the tongue 2 are pressed with a tensioning force against portions of the wall of the groove 3.

[0066] It is clear that, by means of an appropriate dosage, the sliding agent may also be applied over a larger portion of the surface.

[0067] Of course, the use of the sliding agent 12 does not necessarily have to be combined with the use of a surface treatment product.

[0068] In figure 7, the form of embodiment already mentioned in the introduction is represented schematically, whereby the tongue 2 and the groove 3 are treated by means of a mixture of sealing agent and sliding agent, as a result of which a layer of sealing agent 17 and a layer of sliding agent 12A have been formed, whereby the layer of sealing agent 17, for example, polyurethane, substantially is situated in the material of the floor panel 1, whereas the sliding agent 12A, for example, wax, oil or a paraffin, has remained at the outer surface. The set sealing agent 17 prevents the absorption of the sliding agent 12A, as a result of which this latter remains active. Preferably, the wax consists of a viscous compound based on silicone, more particularly polysiloxane-copolymer. A small quantity of even less than 1% in respect to the entire mixture may already suffice.

[0069] Figure 8 shows a schematic enlargement.

[0070] Although the use of a mixture offers the advantage that only one treatment is required for the application, it is clear that the invention also relates to embodiments whereby the sealing agent 17 and the sliding agent 12A are applied on the edge successively.

[0071] It is also clear that the mixture may also be applied in the shape of a strip.

[0072] Figure 9 shows a further variant whereby the technique which is applied in figure 7 is combined further with a local strip of sliding agent 12.

[0073] Figure 10 shows an enlargement from a variant whereby at the location where the floor panels 1 cooperate with each other, in this case, on the contact surfaces 10A and 11A, an elastic coating 18, 19 respectively, is provided which allows for a deformation when a mutual shifting occurs between the actual floor panels 1, in such a manner that there will be no shifting at the location of the contact surface 20 of the coatings 18 and 19.

[0074] In figure 10, the aforementioned deformation is represented schematically in respect to the material portions 21 and 22. When, as the floor covering is stepped on, a shifting V of the contact surface 11A in respect to the surface 10A takes place, the material portions 21 and 22 at the contact surface 20, so to speak, adhere to each other and are deformed to the indicated material portions 21A and 22A. As a result thereof, there will be no shifting of materials over each other, but only a deformation, as a result of which creaking sounds are excluded, at least, however, with a minor deformation.

[0075] It is clear that the sliding agent 12-12A and/or the coatings 18-19, in the case that the floor panels 1 are provided with coupling parts at four sides, can be applied either exclusively along one or both of the longitudinal edges, or along one or both of the longitudinal edges as well as along one or two of the short edges.

[0076] Although the invention proves its usefulness in first instance in such embodiments in which the coupling parts of the tongue-and-groove connection exert a

tioning force upon each other, it is clear that it can also be applied in embodiments in which this tensioning force is not present.

5 Claims

1. Floor covering, consisting of floor panels (1) based on a fibre-like material bound by a binding agent, more particularly MDF or HDF, which, at least at their edges, are connected to each other by means of a connection, more particularly a tongue-and-groove connection (2-3), which connection consists of coupling parts which are made in one piece with the floor panels and is shaped in such a manner that the floor panels (1) are locked glue-free in the direction parallel to the plane of the floor covering and transverse to the connection, as well as in a direction perpendicular to this plane, characterized in that, at least at the location where the floor panels (1) cooperate with each other, a sliding agent (12-12A) is provided at least on one of the floor panels (1).
2. Floor covering according to claim 1, characterized in that the sliding agent (12-12A) is applied in the shape of a layer which, at least partially, is provided on top of the surface concerned, in other words, that the sliding agent manifests itself as "lying on top" on the surface of the floor panel (1).
3. Floor covering according to claim 1 or 2, characterized in that the sliding agent (12-12A) substantially is applied over the entire surface of the edge of at least one of the floor panels (1).
4. Floor covering according to claim 1 or 2, characterized in that the sliding agent (12) is at least applied in the shape of one or more local strips extending in the longitudinal direction of the tongue-and-groove connection (2-3).
5. Floor covering according to claim 4, characterized in that exactly one strip is provided.
6. Floor covering according to claim 4 or 5, characterized in that each respective strip in original undeformed condition has a width of maximum 4 mm.
7. Floor covering according to any of the claims 4 to 6, characterized in that the strip is set remote from the upper edge of the floor panel (1).
8. Floor covering according to claim 7, characterized in that between the upper edge and the strip of sliding agent (12) situated closest to the upper edge, as seen along the contour of the surface, at least one receiving space (13-15-16) is present.

9. Floor covering according to claim 8, characterized in that between the lower edges of the respective floor panels (1) and the strip of sliding agent (12) situated closest to these lower edges, as seen along the contour of the surface, a receiving space (14) is present, too. 5
10. Floor covering according to any of the preceding claims, characterized in that the layer of sliding agent (12-12A), in the original, uncoupled condition of the floor panels (1), has an average thickness of the portion lying on top in the order of magnitude of minimum 0,05 mm or more. 10
11. Floor covering according to any of the preceding claims, characterized in that the sliding agent (12-12A) can be deformed, more particularly, plastically deformed. 15
12. Floor covering according to any of the preceding claims, characterized in that the sliding agent (12-12A) is meltable but is set at room temperature. 20
13. Floor covering according to any of the preceding claims, characterized in that the sliding agent (12-12A) is a wax, in particular paraffin. 25
14. Floor covering according to any of the preceding claims, characterized in that the tongue (2) and/or the groove (3) of the tongue-and-groove connection (2-3) is also treated with a surface treatment product and the sliding agent (12-12A) substantially is present on top of this product. 30
15. Floor covering according to any of the preceding claims, characterized in that the floor panels (1) at least are provided with a sliding agent (12A) consisting of a product which is applied on the respective edge of the floor panel (1) concerned in the shape of a liquid mixture of at least one sealing agent (17) and a sliding agent (12A). 35 40
16. Floor covering according to claim 15, characterized in that the sealing agent (17) consists of polyurethane. 45
17. Floor covering according to claim 15 or 16, characterized in that the sliding agent (12A) consists of a wax, an oil or an oil-like substance. 50
18. Floor covering according to claim 17, characterized in that the wax consists of a viscous compound based on silicone, more particularly polysiloxane-copolymer. 55
19. Floor covering according to any of the claims 16 to 18, characterized in that the aforementioned mixture substantially is applied over the entire surface of the edge and that on top of the mixture, additionally one or more local strips of sliding agent (12) lying on top are applied according to the characteristics of one of the claims 4 to 9.
20. Floor covering according to any of the preceding claims, characterized in that the aforementioned tongue-and-groove connection (2-3) has coupling parts which, in coupled condition, exert a certain tensioning force upon each other and that the aforementioned sliding agent (12-12A) at least is applied on one or more portions of the contact surfaces (10-11) upon which the tensioning force is exerted.
21. Floor covering according to claim 20, characterized in that the coupling parts have such a form that they force the floor panels (1) coupled to each other by these parts towards each other with a tensioning force, whereby the sliding agent (12-12A) at least is present on at least one or more portions of the contact surfaces (10-11) of the tongue (2) and/or the groove (3) where this tensioning force is exerted.
22. Floor covering according to claim 21, characterized in that the coupling parts are designed in such a manner that the tensioning force which forces the floor panels (1) towards each other exerts a pressure substantially on only two locations, on one hand, by means of a band-shaped contact, and even better, line contact, at the location of the upper edge, and, on the other hand, a band-shaped contact at a place which is situated more towards the inside, and that only one strip of sliding agent (12-12A) is provided which then is applied at least on one of the floor panels (1), at the location of the last-mentioned band-shaped contact.
23. Floor covering according to any of the preceding claims, characterized in that the tongue-and-groove connection (2-3) has one or more portions which, when being joined, taken apart, respectively, bend elastically, this as certain portions of the coupling parts, when being joined, taken apart, respectively, are forced over each other with a certain force, and that the aforementioned sliding agent (12-12A) at least is provided at the location of one or more of the portions which have to be forced over each other with a certain force.
24. Floor covering according to claim 23, characterized in that the part of the floor panels (1) which borders the underside of the groove (3) is an elastically bendable lip (7) and that the shape of the tongue (2) and groove (3) is such that the tongue can only be inserted into this groove by bending this lip (7), whereby the sliding agent (12-12A) is applied on this lip (7) or on the portion of the tongue (2) situated opposite thereto.

25. Floor covering according to any of the preceding claims, characterized in that the locking is performed by a protrusion (9) on the tongue (2) and a recess (8) in the wall of the groove (3) and that the sliding agent (12-12A) is provided on this protrusion (9). 5
26. Floor covering, consisting of floor panels (1) based on a fibre-like material bound by a binding agent, more particularly MDF or HDF, which are connected to each other at their edge by a connection, more particularly a tongue-and-groove connection (2-3), which connection has such a shape that the floor panels (1) are locked glue-free in the direction parallel to the plane of the floor covering and transverse to the connection, as well as in a direction perpendicular to this plane, characterized in that at least at the location where the floor panels (1) cooperate with each other, an elastic coating (18-19) is provided at least on one of the floor panels (1) which, when a mutual shifting (V) between the cooperating portions of the actual floor panels (1) occurs, allows for a local deformation, as a result of which the risk of a shifting at the contact surface (20) between the coatings (18-19), or between the coating and the surface of the other floor panel (1), is excluded or at least minimized. 10
15
20
25
27. Floor panel for a floor covering according to any of the preceding claims, characterized in that it is provided at the factory at least at one of its edges with a sliding agent (12) or an elastic coating, such as defined in one or more of the preceding claims. 30
28. Method for realizing a floor panel for a floor covering according to any of the claims 15 to 19, characterized in that it consists in forming a panel; milling a tongue profile and a groove profile at two or more edges thereof; and applying a liquid mixture of sealing agent (17) and sliding agent (12A) on these edges, in such a manner that the sealing agent (17) is absorbed in the material of the floor panel (1), whereas the sliding agent (12A) at least partially remains at the surface. 35
40
45
50
55

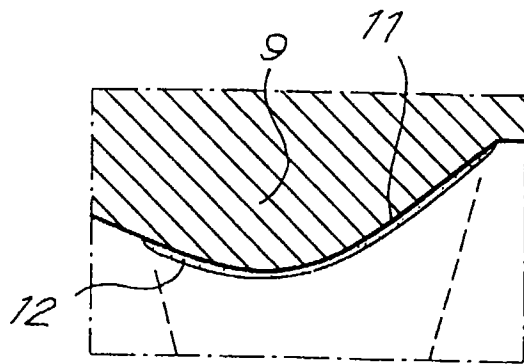
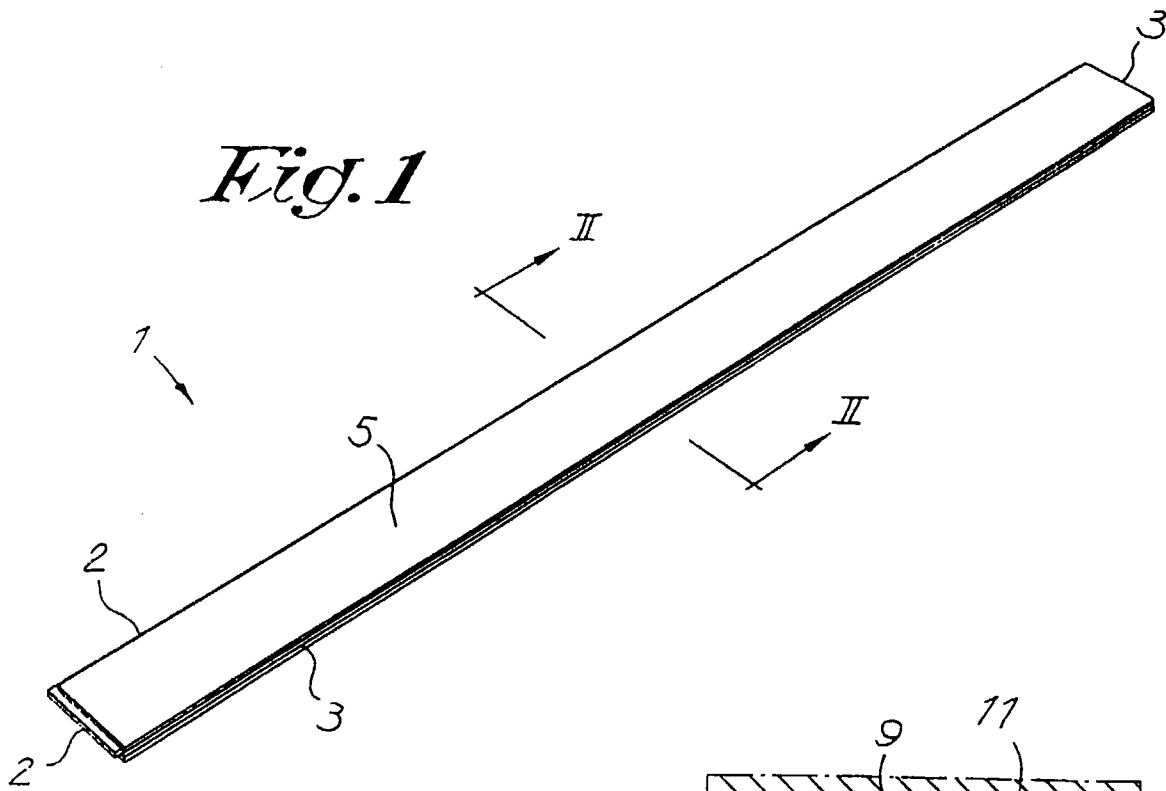

Fig. 3

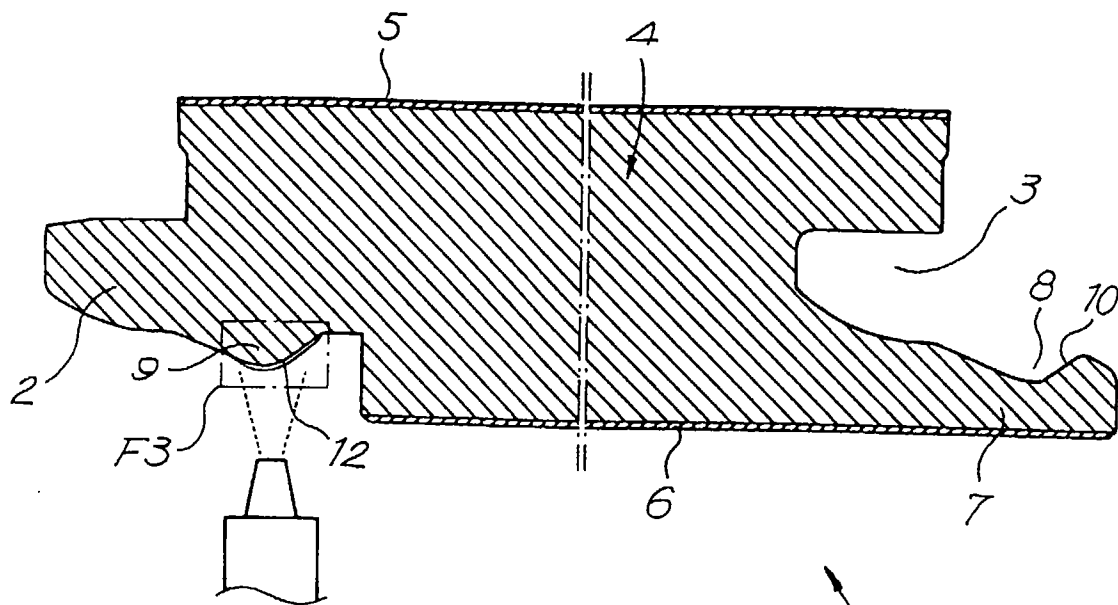

Fig. 2

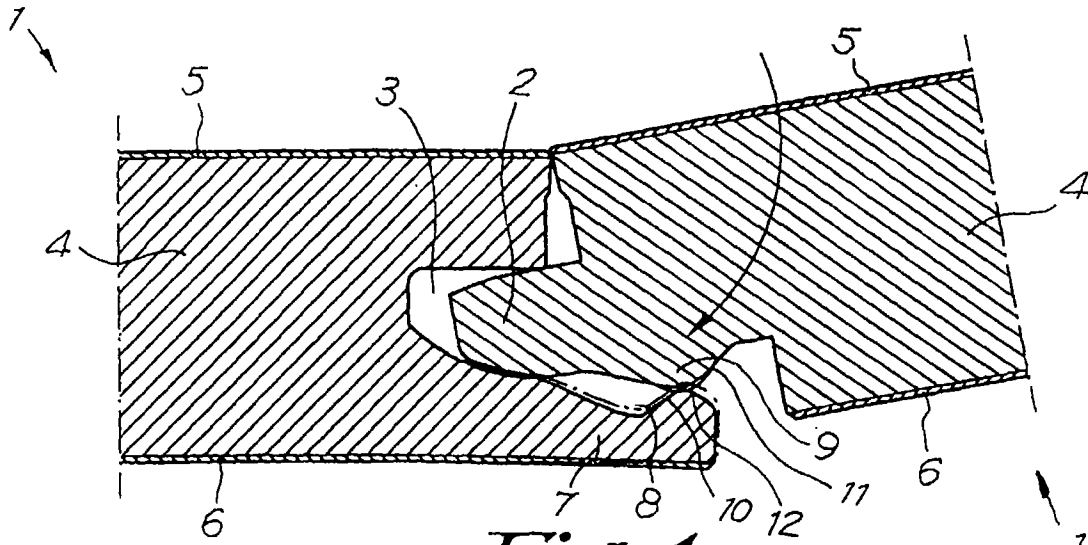

Fig. 4

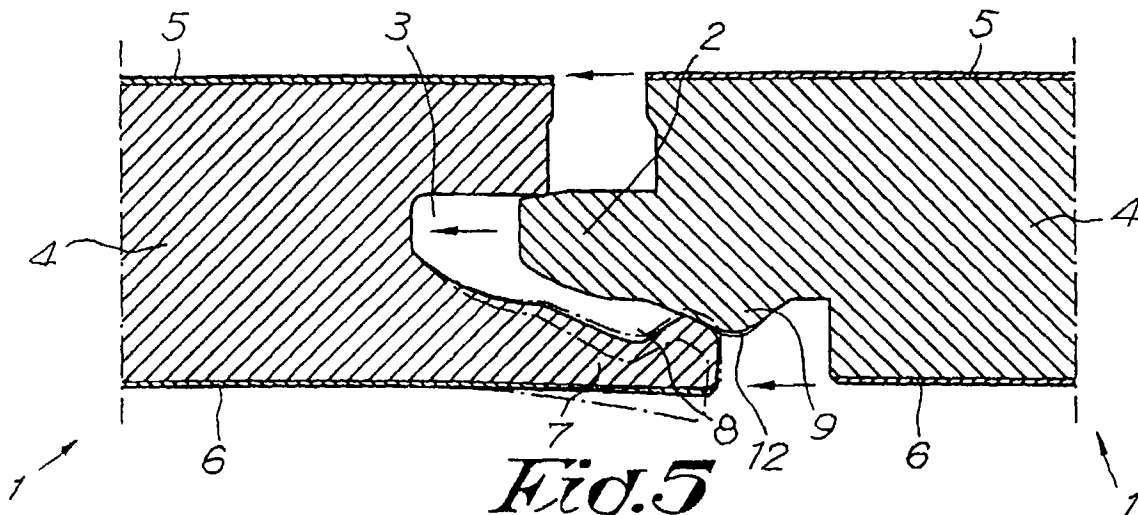

Fig. 5

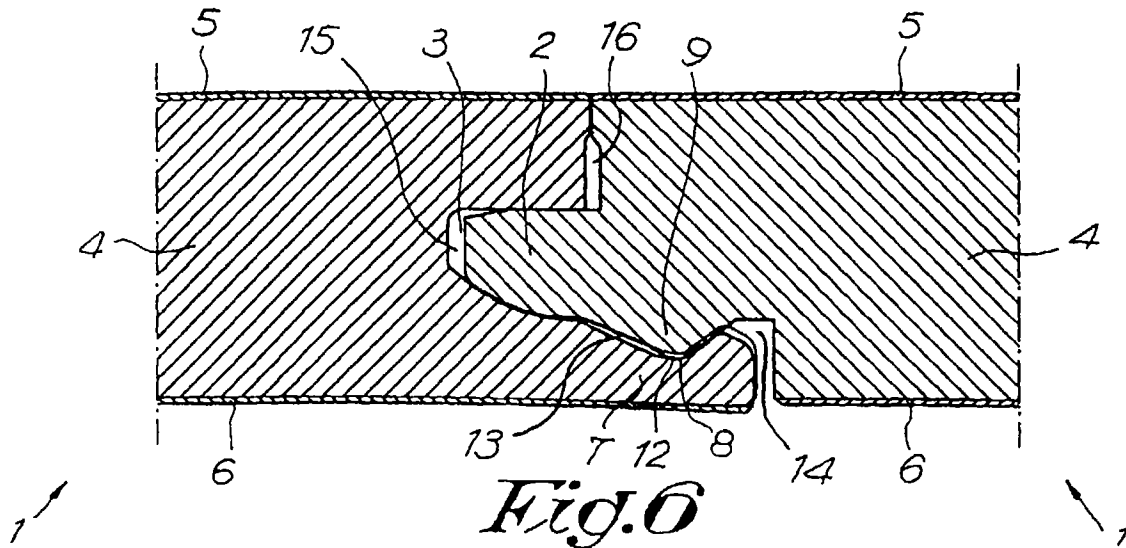

Fig. 6

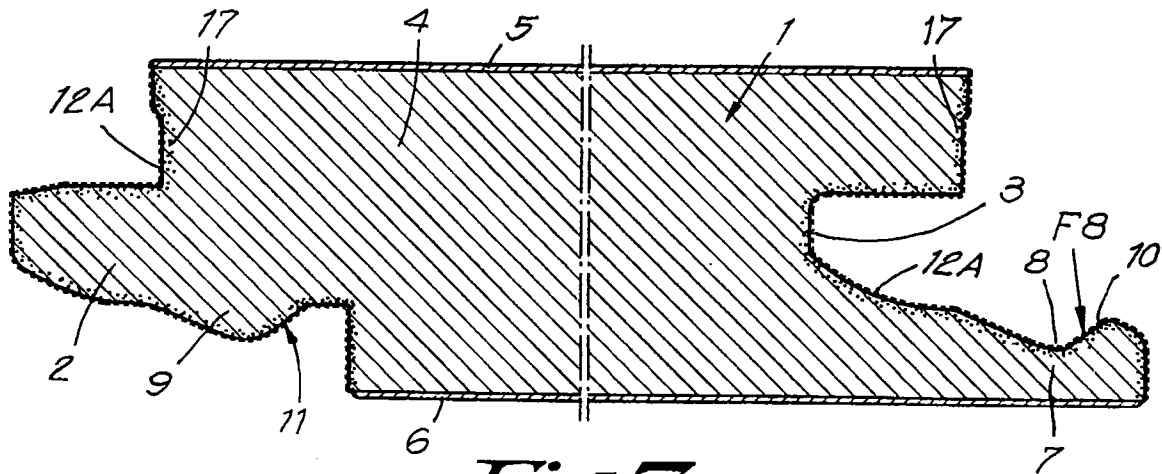

Fig. 7

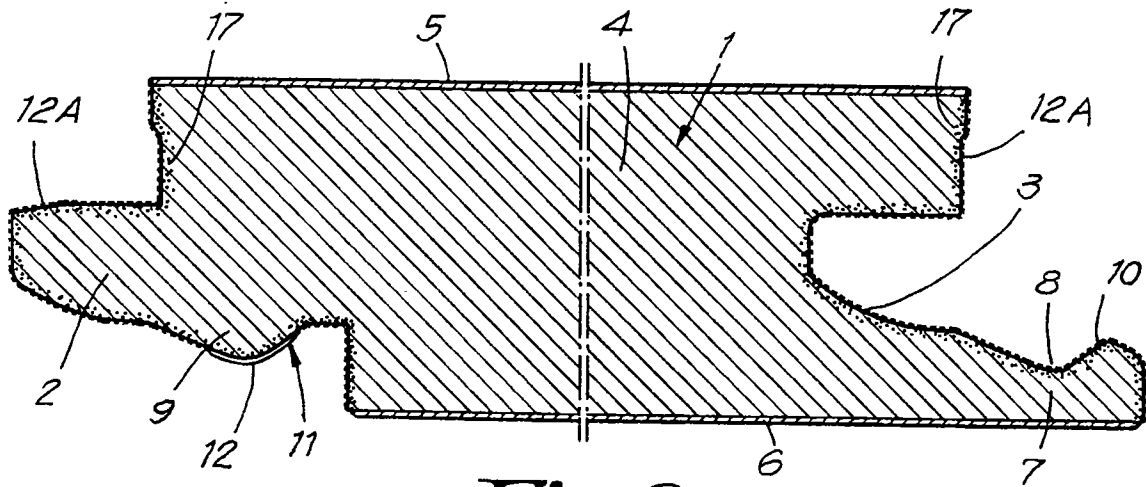

Fig. 9

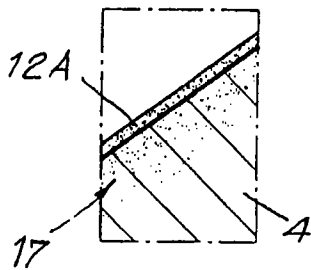

Fig. 8

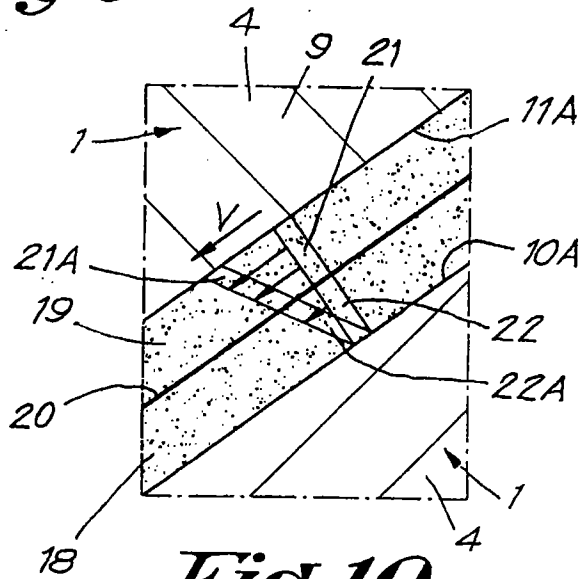

Fig. 10



European Patent
Office

EUROPEAN SEARCH REPORT

Application Number
EP 99 20 2272

DOCUMENTS CONSIDERED TO BE RELEVANT			
Category	Citation of document with indication, where appropriate, of relevant passages	Relevant to claim	CLASSIFICATION OF THE APPLICATION (Int.Cl.7)
D,A	DE 297 10 175 U (UNILIN BEHEER BV) 14 August 1997 (1997-08-14) * page 8, line 31 - page 18, line 18 * * page 19, line 11 - page 28, line 13; figures 1-11,22-25 * ---	1,15, 20-26,28	E04F15/04
A	WO 94 26999 A (PERVAN TONY ;VALINGE ALUMINIUM AB (SE)) 24 November 1994 (1994-11-24) * page 11, line 26 - page 14, line 37 * * page 15, line 30 - page 19, line 5; figures 1-2C,4A-5 * ---	1,26	
A	WO 96 27719 A (MAARTENSSON GOERAN ;PERSTORP FLOORING AB (SE)) 12 September 1996 (1996-09-12) * page 3, line 28 - page 5, line 18; figures 1-4 * ---	1,26	
A	US 5 497 589 A (PORTER WILLIAM H) 12 March 1996 (1996-03-12) * column 1, line 57 - line 63 * * column 2, line 6 - line 42 * * column 6, line 31 - column 7, line 16; figures 3-7 * -----	1,26	TECHNICAL FIELDS SEARCHED (Int.Cl.7) E04F B27M
The present search report has been drawn up for all claims			
Place of search THE HAGUE		Date of completion of the search 1 November 1999	Examiner Ayiter, J
CATEGORY OF CITED DOCUMENTS		T : theory or principle underlying the invention E : earlier patent document, but published on, or after the filing date D : document cited in the application L : document cited for other reasons ----- & : member of the same patent family, corresponding document	
X : particularly relevant if taken alone Y : particularly relevant if combined with another document of the same category A : technological background O : non-written disclosure P : intermediate document			

**ANNEX TO THE EUROPEAN SEARCH REPORT
ON EUROPEAN PATENT APPLICATION NO.**

EP 99 20 2272

This annex lists the patent family members relating to the patent documents cited in the above-mentioned European search report. The members are as contained in the European Patent Office EDP file on
The European Patent Office is in no way liable for these particulars which are merely given for the purpose of information.

01-11-1999

Patent document cited in search report	Publication date	Patent family member(s)	Publication date
DE 29710175 U	14-08-1997	BE 1010339 A	02-06-1998
		BE 1010487 A	06-10-1998
		AU 3256997 A	07-01-1998
		BG 62216 B	31-05-1999
		BG 102230 A	30-09-1998
		BR 9702325 A	09-03-1999
		CA 2226286 A	18-12-1997
		CN 1195386 A	07-10-1998
		CZ 9800391 A	12-08-1998
		WO 9747834 A	18-12-1997
		EP 0843763 A	27-05-1998
		NO 980569 A	10-02-1998
		PL 324923 A	22-06-1998
		SI 9720009 A	31-08-1998
		SK 16398 A	09-09-1998
		WO 9426999 A	24-11-1994
AT 171238 T	15-10-1998		
AU 671919 B	12-09-1996		
AU 6763094 A	12-12-1994		
BG 61457 B	29-08-1997		
BG 100126 A	28-06-1996		
BR 9406718 A	06-02-1996		
CA 2150384 A	24-11-1994		
CN 1122623 A	15-05-1996		
CZ 9502852 A	15-05-1996		
DE 69413391 D	22-10-1998		
DE 69413391 T	04-02-1999		
EP 0698162 A	28-02-1996		
EP 0855482 A	29-07-1998		
EP 0877130 A	11-11-1998		
ES 2122280 T	16-12-1998		
FI 951211 A	15-03-1995		
HU 75843 A, B	28-05-1997		
JP 8510022 T	22-10-1996		
LV 11491 A	20-08-1996		
LV 11491 B	20-02-1997		
NO 950790 A	22-05-1995		
NO 986137 A	22-05-1995		
NO 993136 A	24-06-1999		
NZ 266232 A	26-11-1996		
PL 311568 A	19-02-1996		
SE 9301595 A	17-10-1994		
SG 47518 A	17-04-1998		
SK 141195 A	06-11-1996		
US 5860267 A	19-01-1999		

ANNEX TO THE EUROPEAN SEARCH REPORT
ON EUROPEAN PATENT APPLICATION NO.

EP 99 20 2272

This annex lists the patent family members relating to the patent documents cited in the above-mentioned European search report. The members are as contained in the European Patent Office EDP file on
The European Patent Office is in no way liable for these particulars which are merely given for the purpose of information.

01-11-1999

Patent document cited in search report	Publication date	Patent family member(s)	Publication date
WO 9426999 A		US 5706621 A	13-01-1998
WO 9627719 A	12-09-1996	SE 502994 C AU 5017696 A SE 9500809 A	04-03-1996 23-09-1996 04-03-1996
US 5497589 A	12-03-1996	US 5628158 A	13-05-1997